



# III Congreso Iberoamericano de Soluciones Sistémicas para la Transformación de las Organizaciones



## The Cybernetics of Crisis: Covid-19 in a Federation

Markus Schwaninger, University of St. Gallen, Switzerland

1 December 2021

[markus.schwaninger@unisg.ch](mailto:markus.schwaninger@unisg.ch)

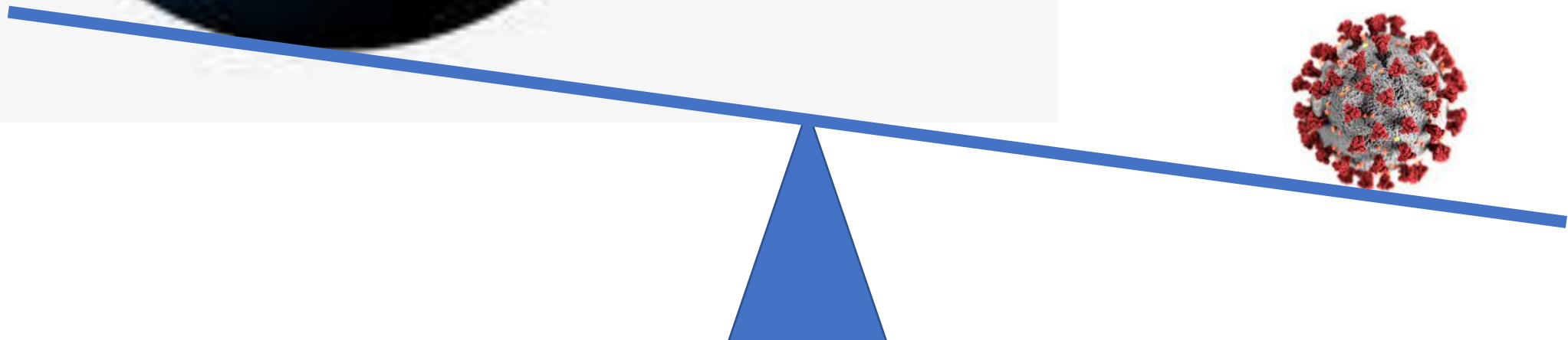
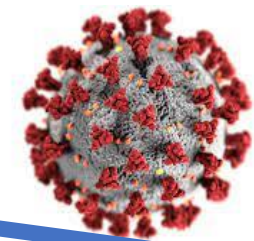

Forthcoming  
17 January 2022:

[markus.schwaninger@unisg.ch](mailto:markus.schwaninger@unisg.ch)



# European Union and Switzerland



# Content

1. Introduction
2. Case
3. Methodology
4. System in Focus: Federation
5. Diagnosis
6. Design
7. Reflection

## Purpose of Study

... to diagnose the status quo  
and make suggestions

for the design of organizational improvements

# Research Questions

1. How is the management of the corona crisis organized in Switzerland?
2. How effective is this organization in coping with the dynamics of emergency?
3. What lessons can be learned for crisis management in the future?

→ Methodological Framework:

**The Viable System Model – VSM (after Stafford Beer)**

# New Corona cases per day (7-day-average)

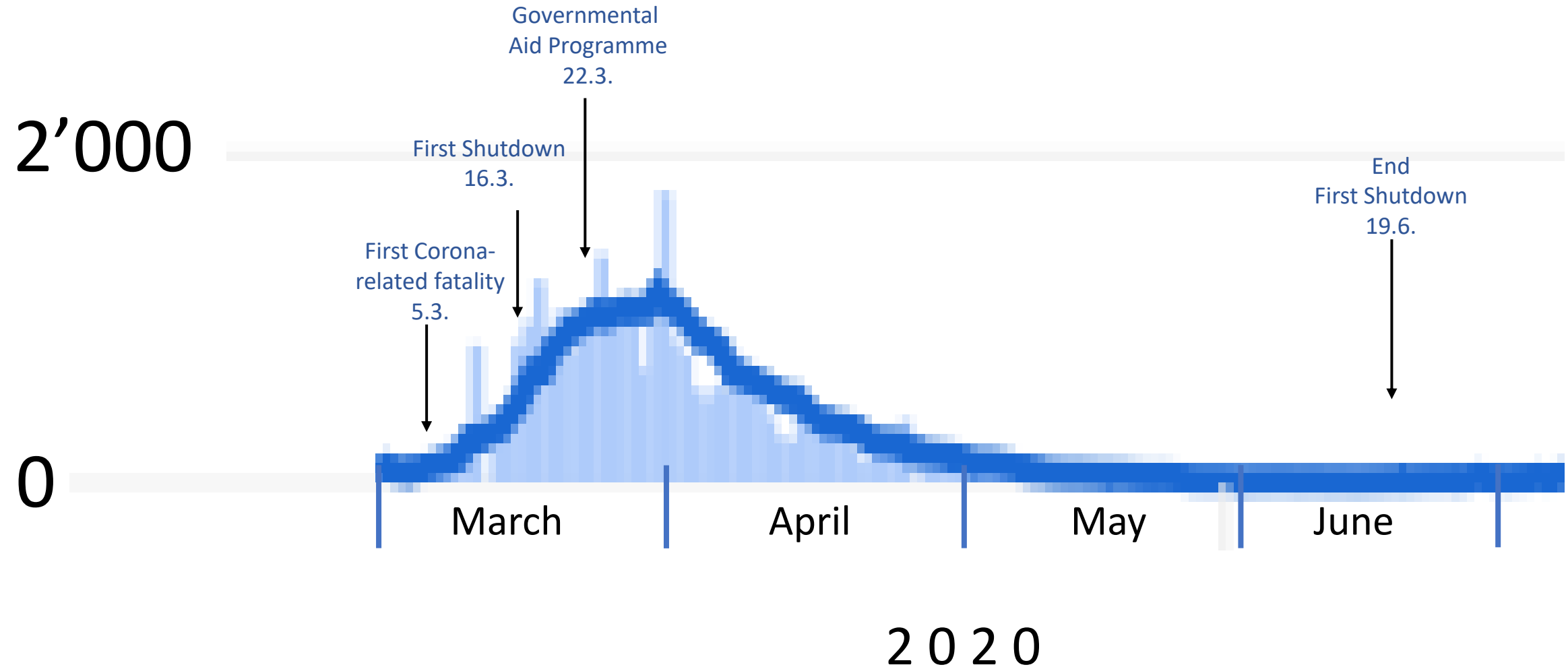



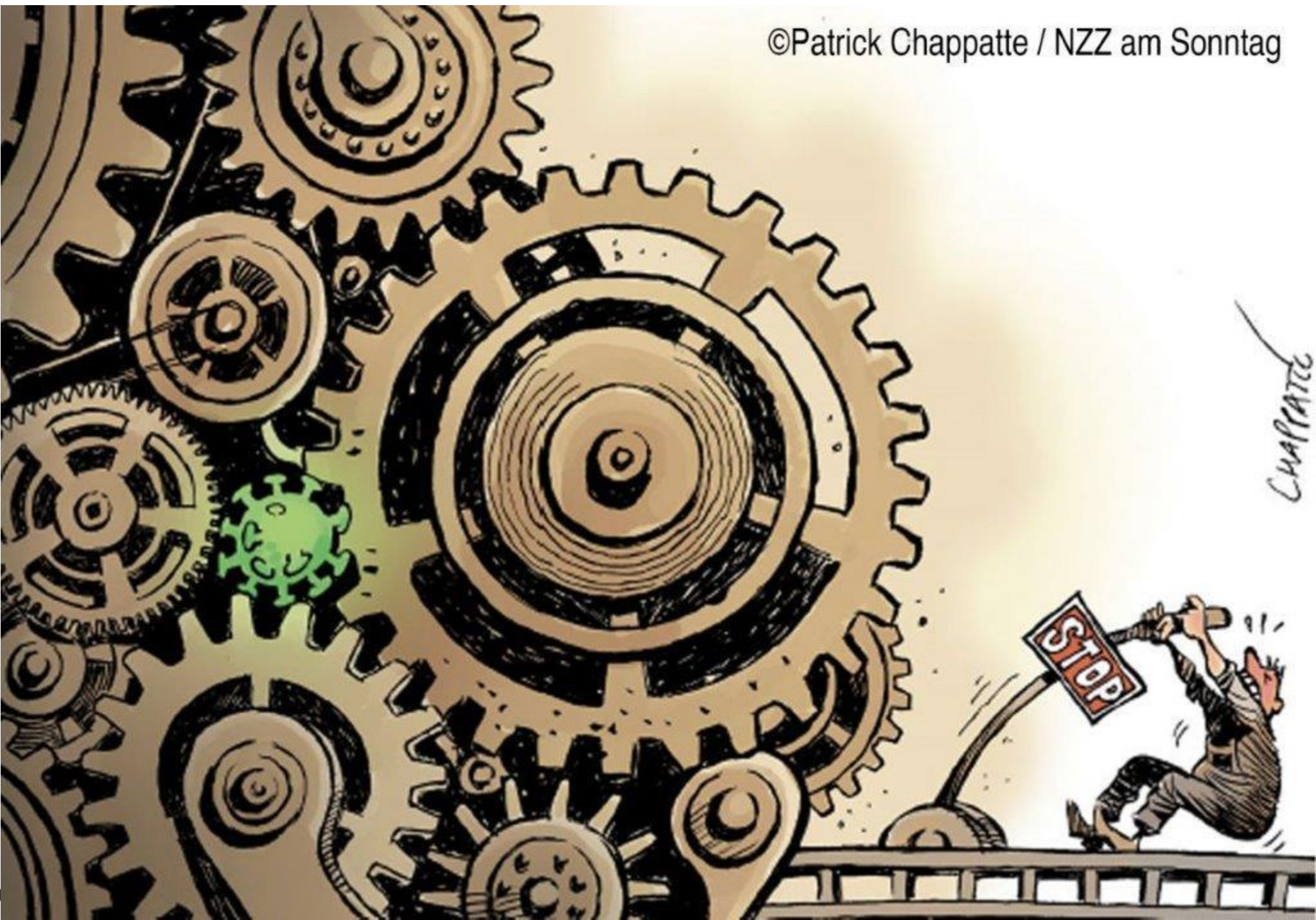

# New Corona cases per day (7-day-average)



New  
Corona  
cases per  
day  
(Switzer-  
land)



- ① First Shutdown: Closure of shops, restaurants and leisure facilities (16 March 2020)
- ② Opening of schools, shops and restaurants (11 May 2020)
- ③ Nationwide closure of restaurants and leisure facilities (22 December 2020)
- ④ Second shutdown. Shop closures and compulsory home office (18 January 2021)
- ⑤ Opening of shops (1 March 2021)
- ⑥ Restaurant terraces open, indoor sports allowed again (19 April 2021)
- ⑦ Open restaurants, relax upper limits on attendance of events and meetings (31 May 2021)
- ⑧ Obligatory certificate in restaurants and leisure institutions (13 September 2021)

# A peculiar path of crisis management

1. The sovereign is the highest authority. The Confederation relies on citizens' self-control in complying with rules and regulations.
2. The Government is constituted by 7 members of the Federal Council, - the **“BUNDESRAT”**. These are ministers. All decisions are made consensually.
3. The rule of law defines two types of situations (besides the normal situation) for which special powers are granted:
  - A) Special Situation: Epidemiological urgency (H1N1, SARS)
  - B) Extraordinary Situation: National threat (Flu in 1918, Covid 19)
4. Lockdown ≠ Shutdown
5. Regulations were less severe than in most other countries.



# New Corona cases per day (Switzerland)

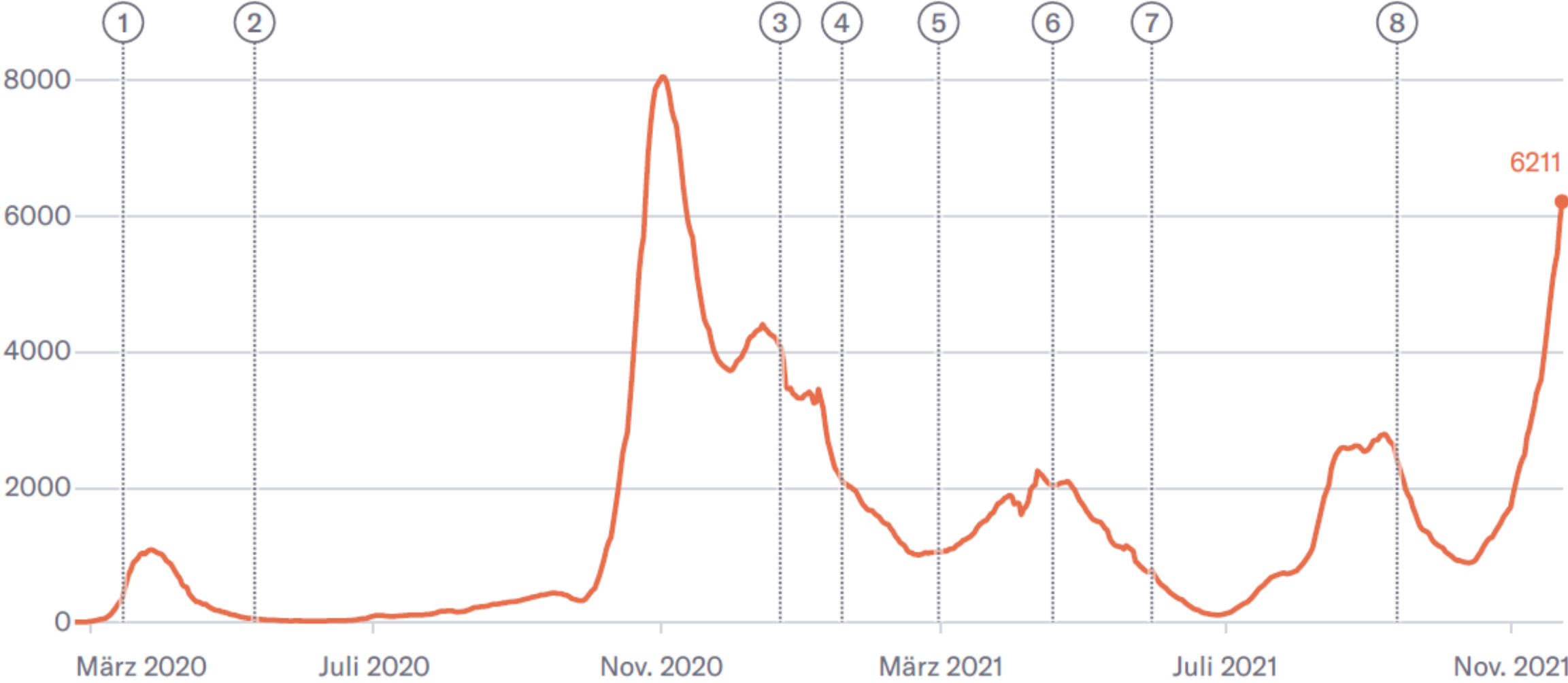

# The System-in focus: a Federation

## Federation = the form of state

- a union of partially self-governing provinces, states, or other regions under a central federal government (federalism).
- The self-governing status of the component states, as well as the division of power between them and the central government, ... may not be altered by a unilateral decision of either party.

# Democracy

Democracy = the form of rule or form of governance

- The word “democracy” comes from the Greek and means "rule of the people".
- That is, in democracy, the people are the state sovereign (the supreme power of the state) and political decisions are made by the majority will of the people.
- Direct democracy in Switzerland is structured in such a way that the electorate, as the sovereign at all levels of the state (municipality, canton, federal state), can make final decisions on substantive issues as the holder of the supreme power (sovereign).

# System of Government

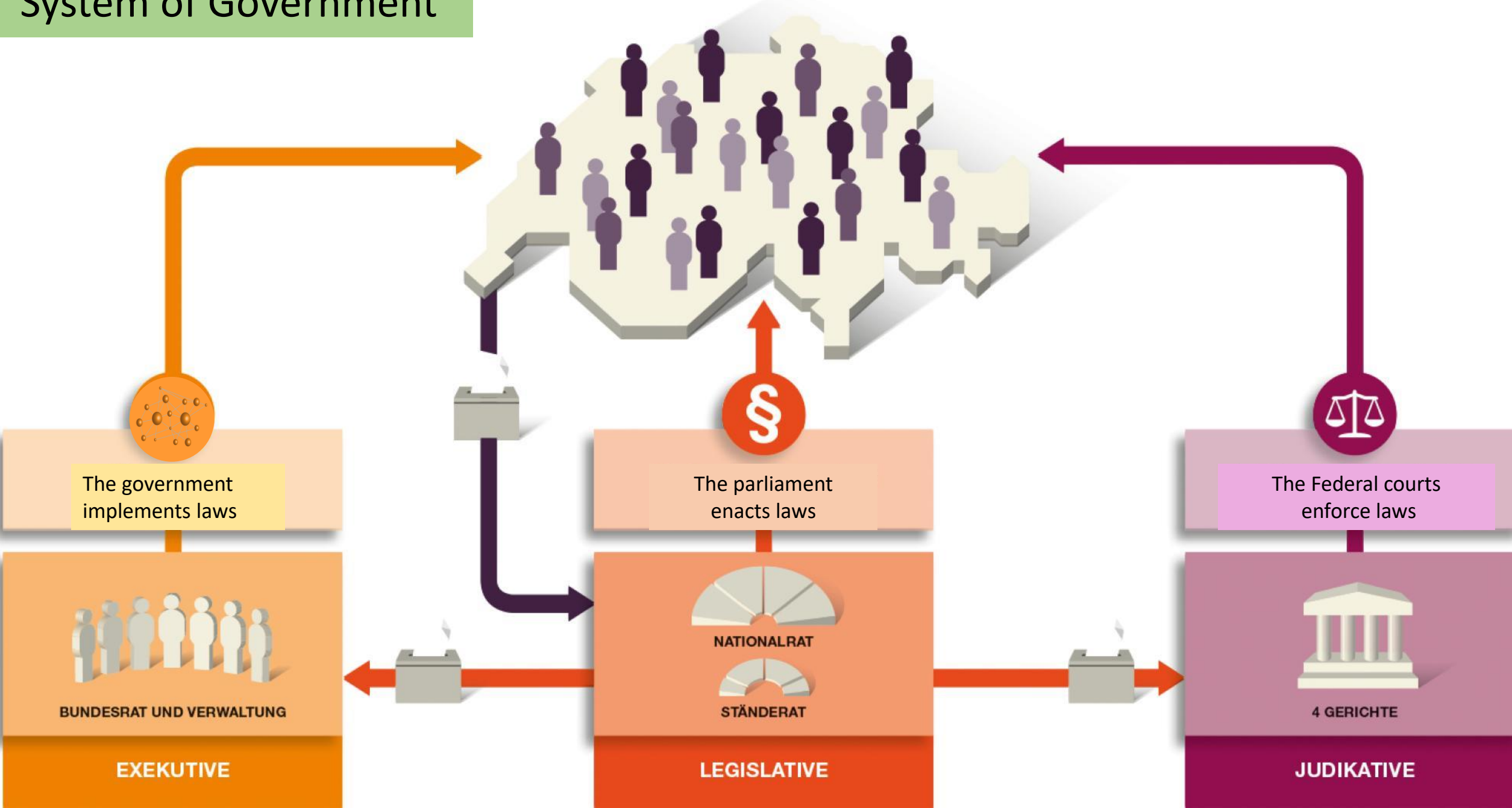



# Levels of Recursion considered

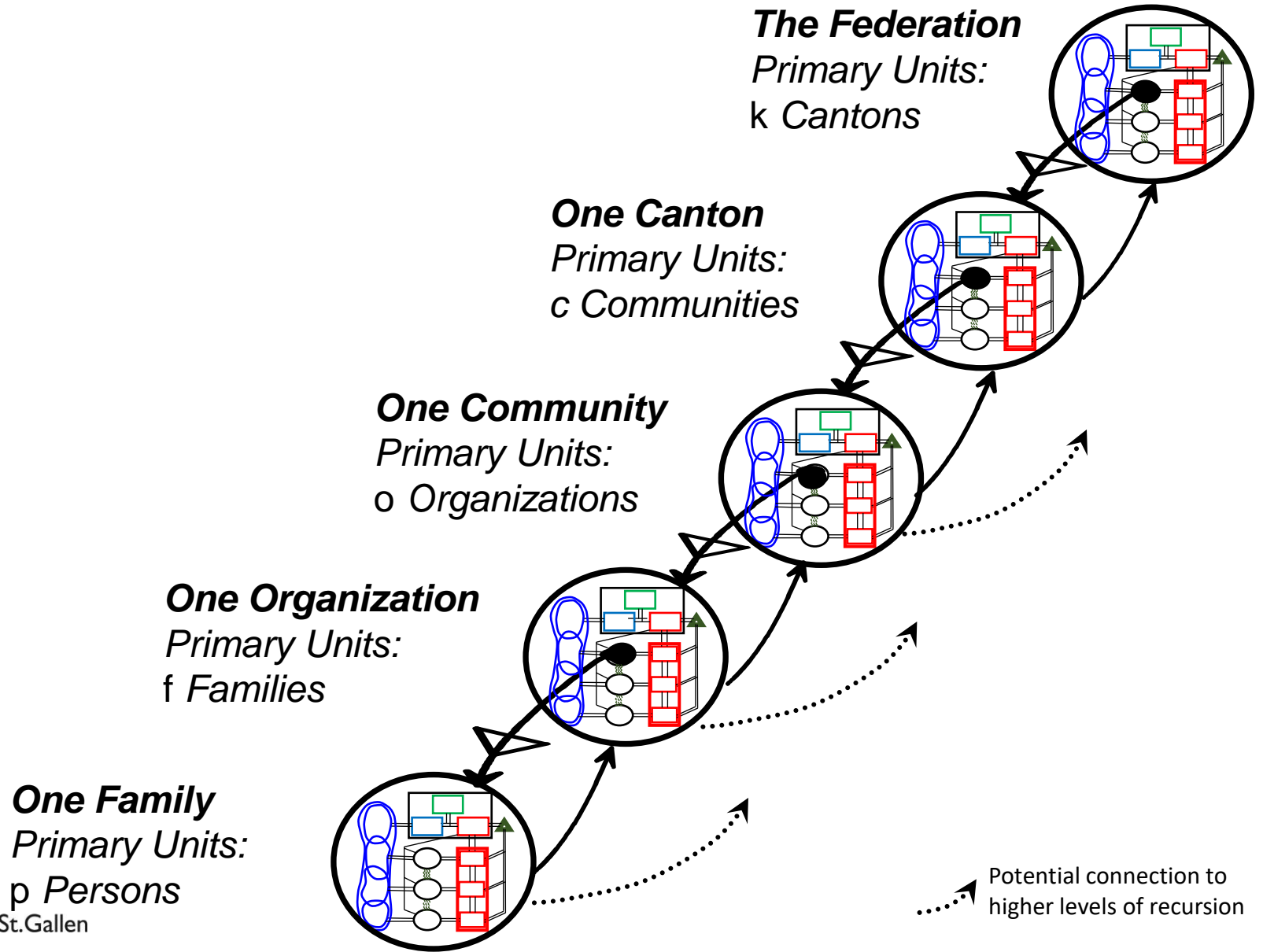

## A Federation: The 26 states of Switzerland



## Direct Vote in Communities and Cantons





# «Landsgemeinde Appenzell»: Lands Community - Last Sunday of April



# Bottom-Up-Governance The Sovereign is the People

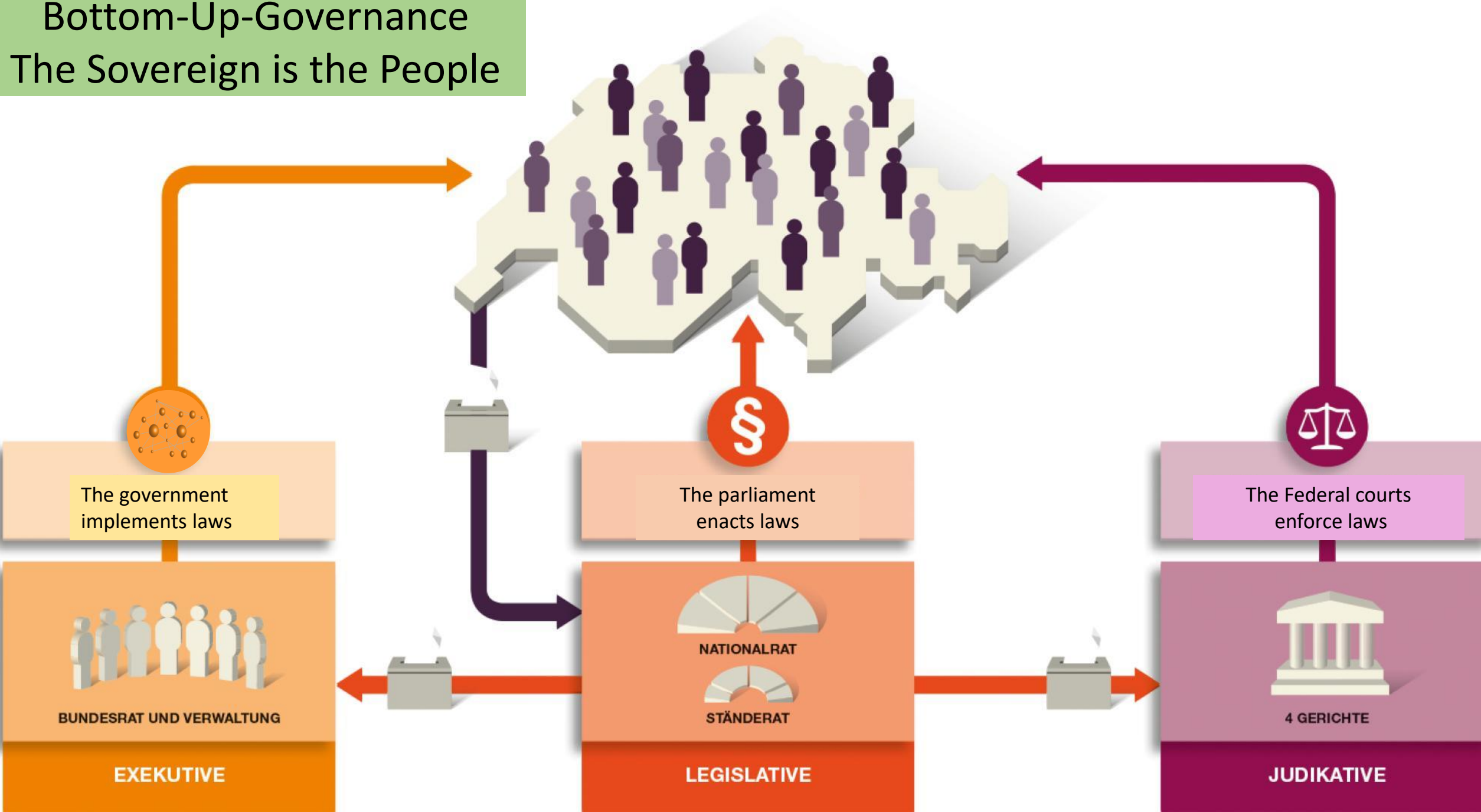



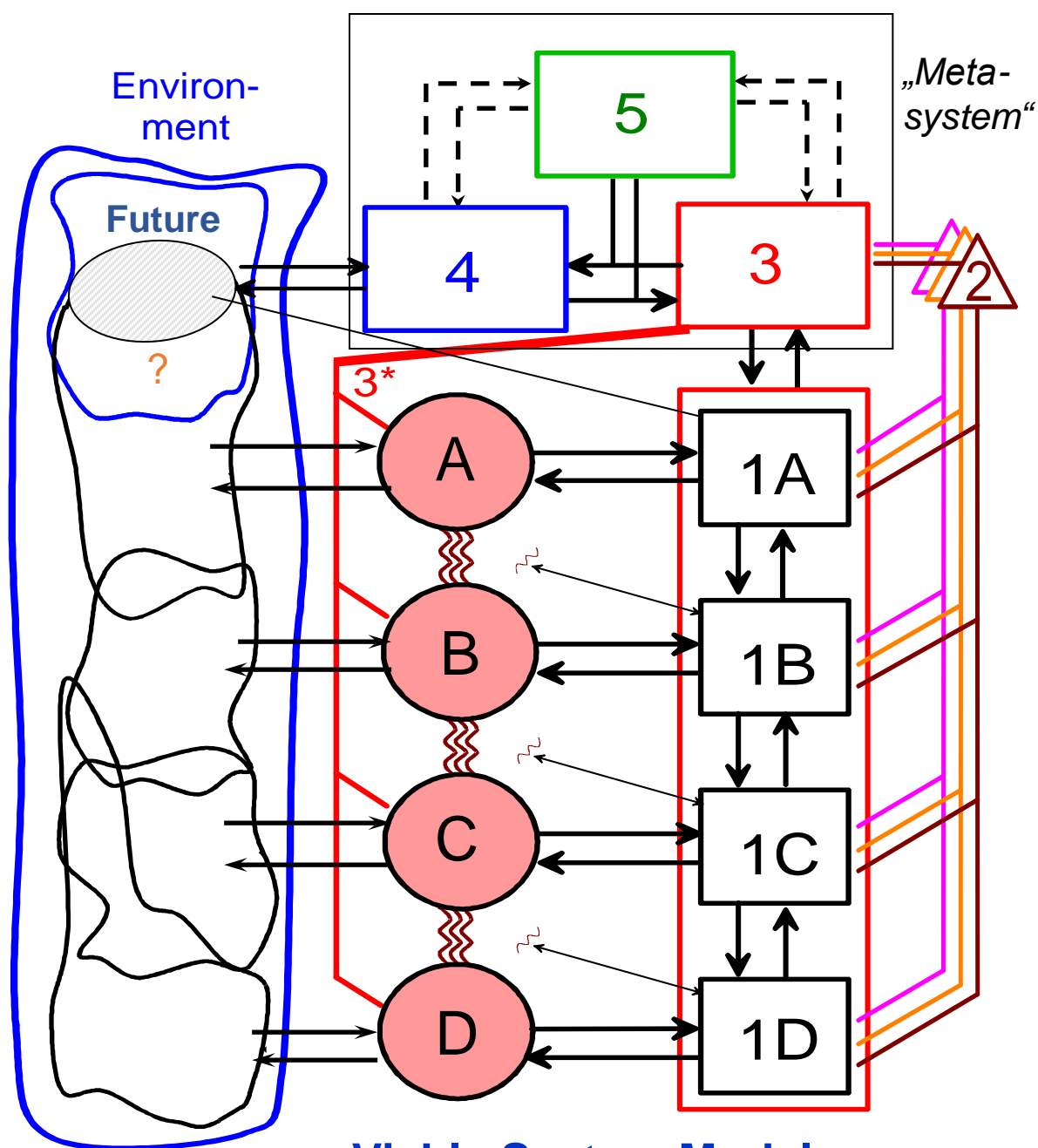

**Viable System Model**  
**Example Firm**

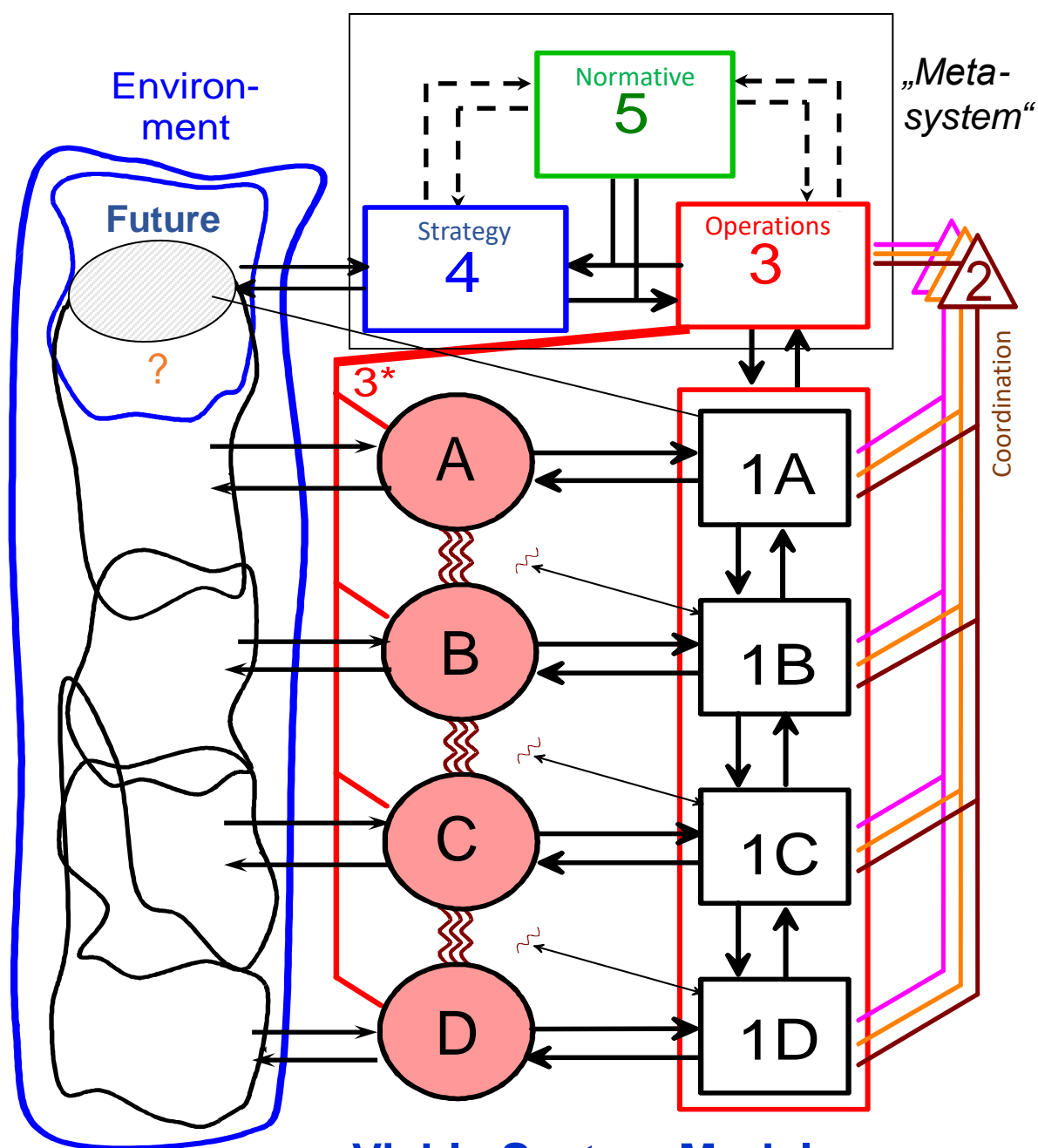

**Viable System Model**  
**Example Firm**

VSM  
after  
Beer

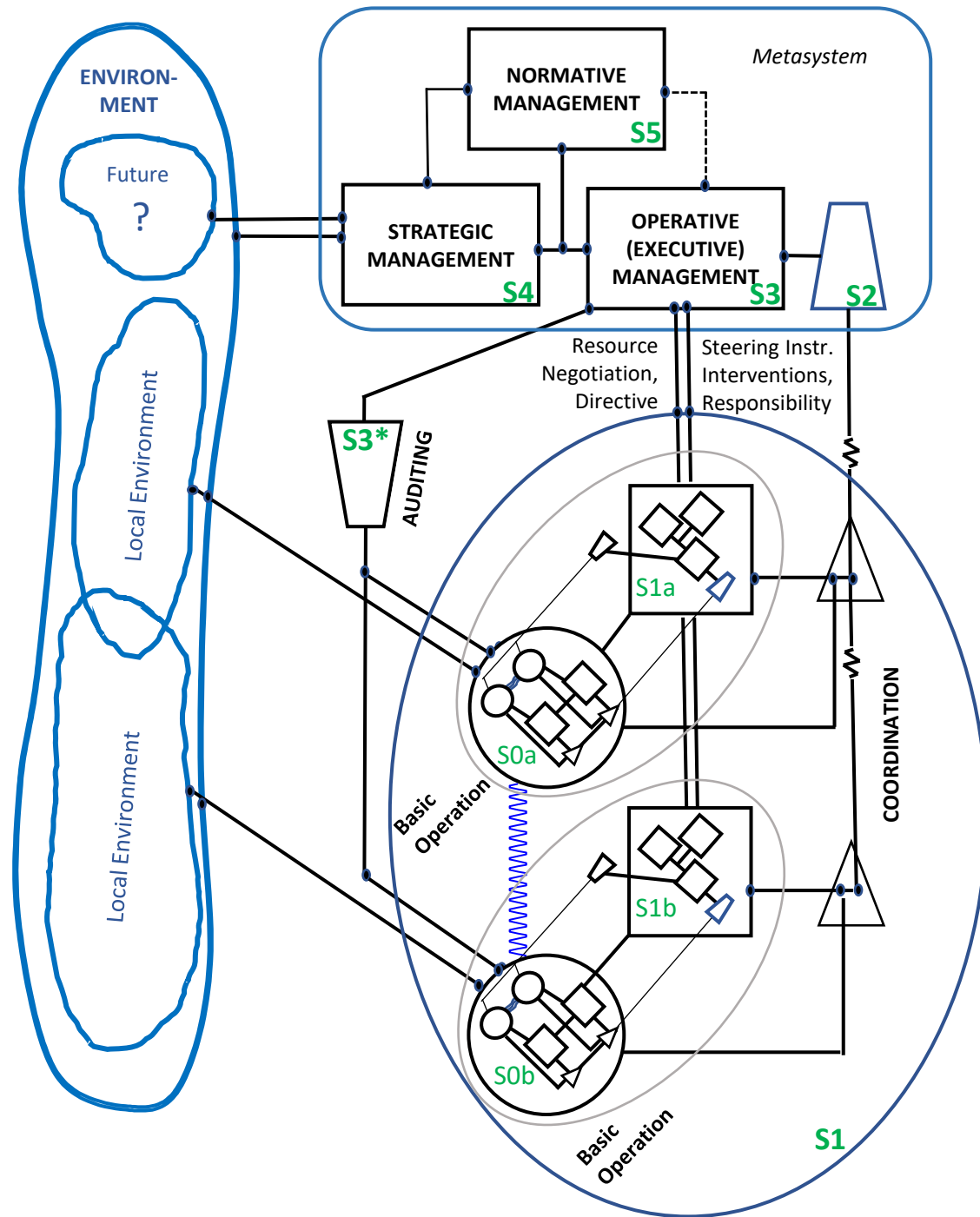



VSM  
after  
Beer

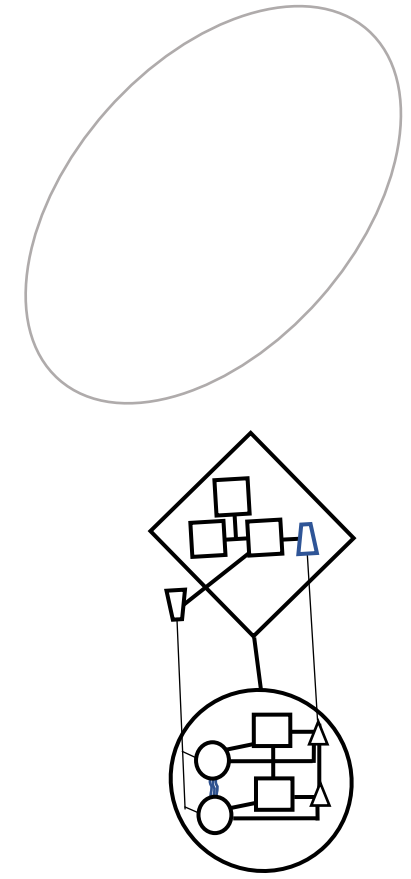
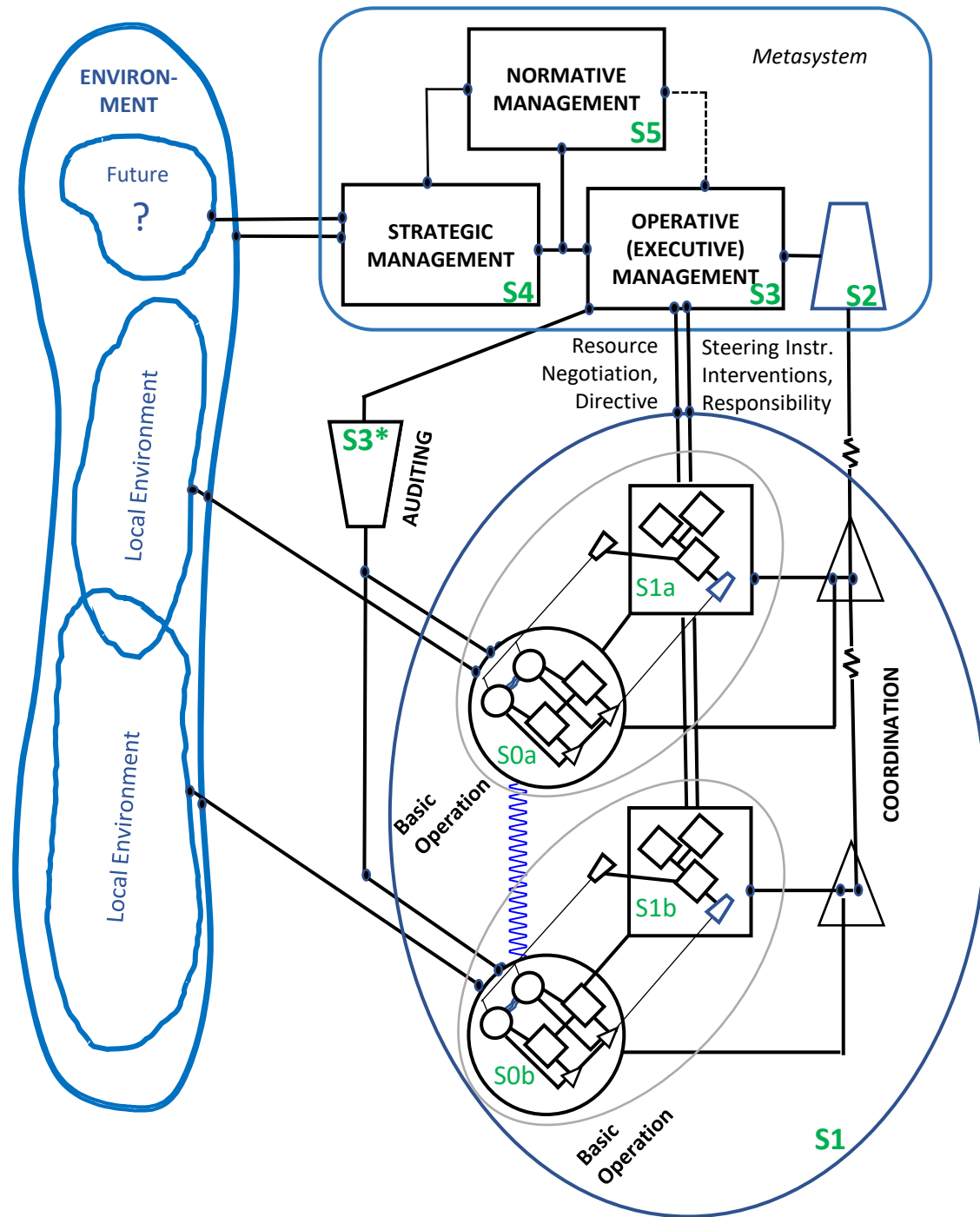

**Actual Structure  
Federal Level**

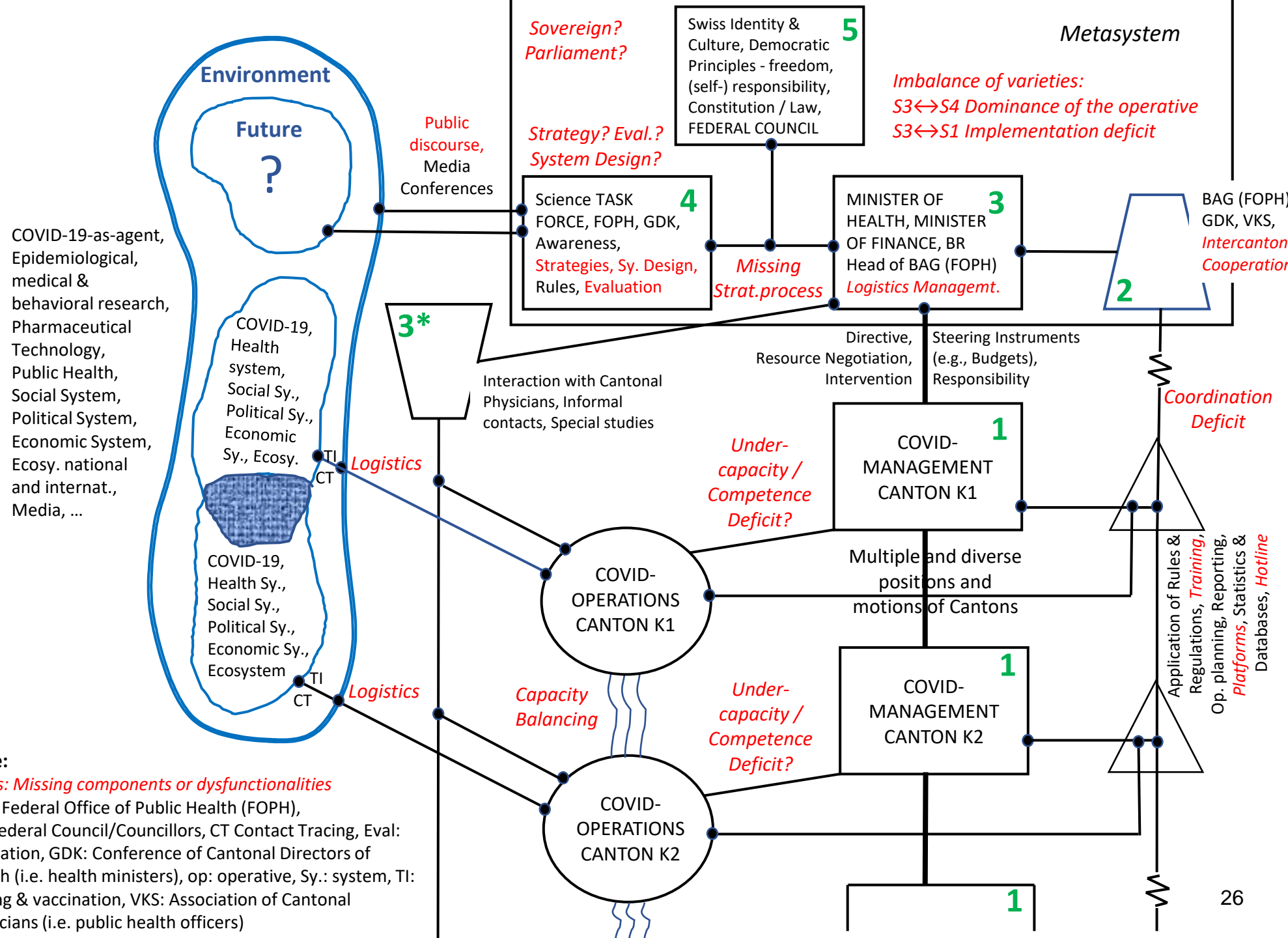

# Diagnosis and Design

## 50 Basic Units – The Cantons

### Actual

- Highly autonomous bodies
- Skilled and equipped to maintain viability
- Shortcomings in the realization of strategies
- Laggards in strategy realization
- Short of Capacity/competency.  
Examples: provision of infrastructure  
– testing, vaccination

### Measures

- Take back isolationist attitude
- Adopt open mindset
- Enhance cooperation and coordination
- Support from a national organ

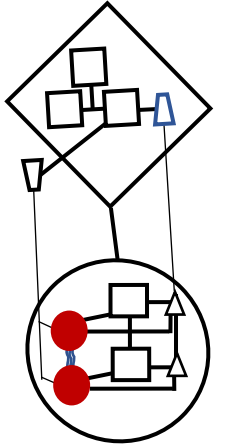

# S1 Local Management & the channel Environment ↔ S1

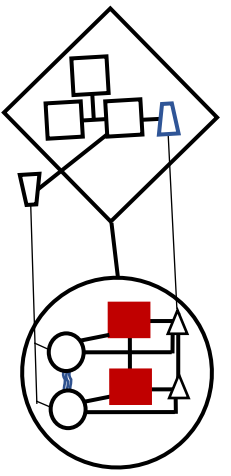

## Actual

- Varying forms of enforcement of national guidelines and measures are typical of the federal system
- Differing performance between Cantons
- Cantons are often overburdened: in implementation tasks  
(e.g.enforcement of rules and regulations, control of protection concepts, realization of testing and vaccination campaigns)

→ How can crisis management at the cantonal level gain coherence and clout?

## Measures

- Build-up of eigen-variety vis-à-vis the active virus
- Attenuation of the complexity (foreign variety) of the active virus
- Reinforce intervention powers of Federal Government for “special situation”
- Leadership education / organization development for cantonal politicians and staff

# S2 Coordination & the channel S1 ↔ 2 ↔ 3

## Actual

- The autonomous cantons are reluctant to coordination
- This is based on the federalist principle of self-determination
- Coordination out of reach?
- Certain organs perform a coordinative function (FOPH, GDK, VKZ )\*
- GDK is the closest to fulfilling a coordinative function\*\*, but
- Would not be able to decide quickly enough in a crisis
- p.m. information systems

## Measures

- Anchor coordination role in GDK statutes
- Strengthen training → Organization Development with the cantonal authorities
- (Re-) Design / Improve Communication and Information Systems substantially, - platforms and data management in particular
- Coordinative function of the warning system
- Hotline for information of cantonal staff

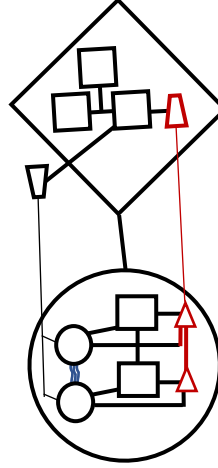

\*FOPF: Federal Office of Public Health GDK: Conference of the Cantonal Health Ministers

VKZ: Association of Cantonal Physicians \*\*Members seeking agreement on proposals to govt.

# S3, Operative (“Executive Management”) & channel S1 ↔ S3

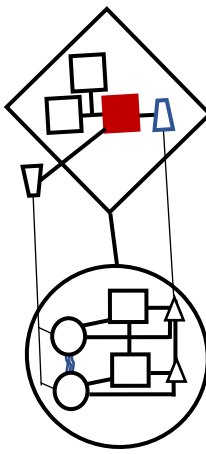

## Actual

- General Mgt. Is with Minister of Health plus FOPH-BAG
- Selectively supported by Minister of Finance (finance and logistics)
- In principle, all major decisions are taken by the integral federal council.
- The 7 councillors are in demand also at S4 and S5 (Strategic & Normative Mgt.)
- Members of government can hardly cope with the complexity
- Variety deficit in particular with Minister of Health
- The power to issue commands is offset by a lack of enforcement and sanctioning power
- Logistics management shows deficits

# Core Problem: Disequilibrium I

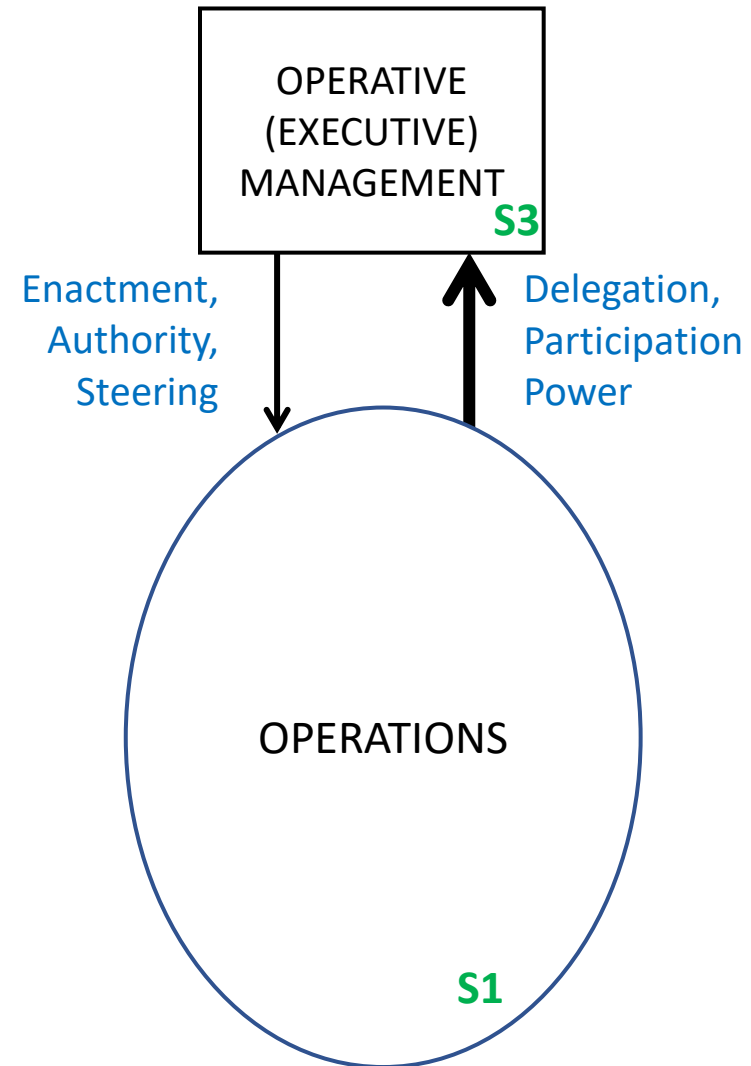

Disparity: Vertical Imbalance S1-S3

## S3, Operative (“Executive Management”) & channel S1 ↔ S3

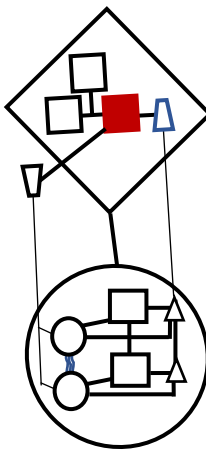

### Actual

- General Mgt. Is with Minister of Health plus FOPH-BAG
- Selectively supported by Minister of Finance (finance and logistics)
- In principle, all major decisions are taken by the integral federal council.
- The 7 councillors are in demand also at S4 and S5 (Strategic & Normative Mgt.)
- Members of government can hardly cope with the complexity
- Variety deficit in particular with Minister of Health
- The power to issue commands is offset by a lack of enforcement and sanctioning power
- Logistics management shows deficits

### Measures

- Reduce the timely commitment to S3 for the members of the Federal Council, and
- Create an operational body «Crisis Staff» (type of General Staff)
- This organ could also be headed by one of the Federal Councillors, but it would include mainly key persons from outside the council
- Acts as a responsible decision-making body with special powers of authority



# S3\* Auditing Channel

## Actual

- Interaction FOPH with cantonal physicians
- Informal contacts with cantonal officials
- i.e., information periphery – center
- Early warning system - information collections, reporting obligations of physicians regarding infectious diseases
- Evaluations of law enforcement

## Measures

- Collect inputs for improvement of Covid crisis management (feedback)
- Sampled visits to Cantons
- Better use of data
- Adapt Information & Communication systems
- Install early warning system / algedonic channel (alarm function)

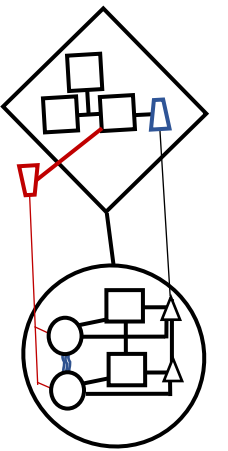

# S4 Intelligence / Development / Strategic Management & channels Environment ↔ S4, S3 ↔ S4

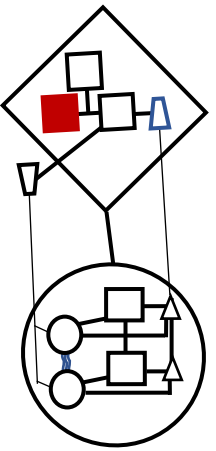

## Actual

- **Scientific Task Force** since 3/2020
  - Big, clumsy
  - Powerless
- **Long-term perspective weak/at risk**
- This has improved in 2021
- Security Alliance Exercise 2014: recommendations fully neglected
- System design: contributions by FOPH
- A holistic, long-term approach to system design is still to evolve
- Lack of an ongoing evaluation

# Core Problem: Disequilibrium II

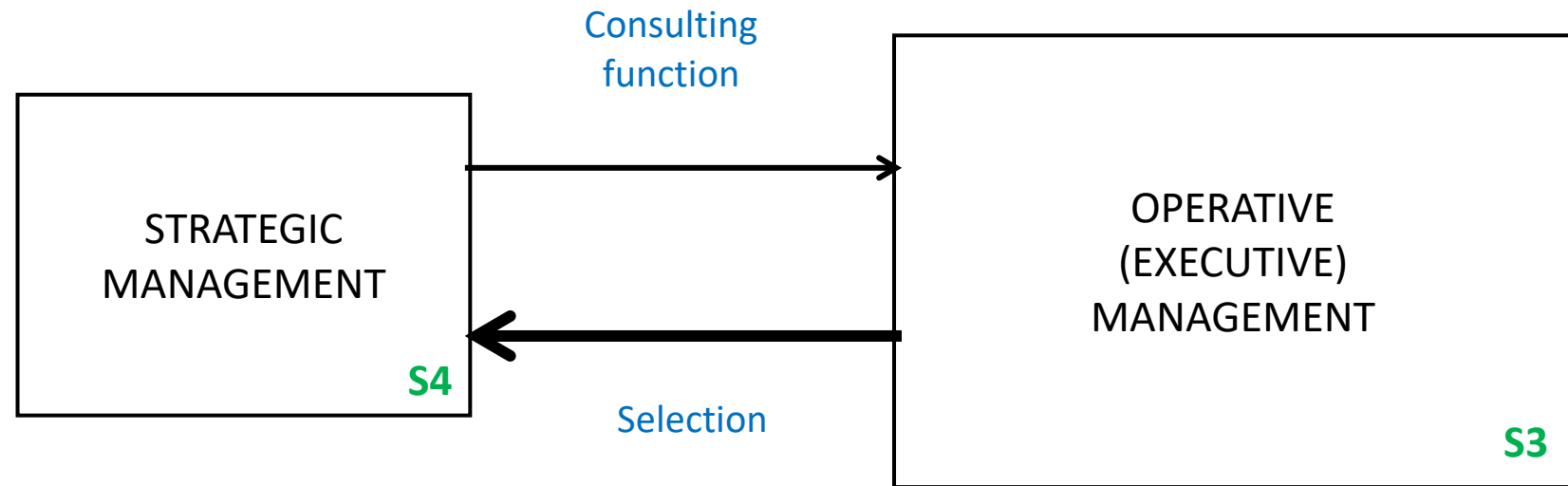

Disparity: Horizontal Imbalance S3-S4

# S4 Intelligence / Development / Strategic Management

*& channels Environment ↔ S4, S3 ↔ S4*

## Actual

- Scientific Task Force since 3/2020
  - Big, clumsy
  - Powerless
- Long-term perspective weak/at risk
- This has improved in 2021
- Security Alliance Exercise 2014: recommendations fully neglected
- System design: contributions by FOPH
- A holistic, long-term approach to system design is still to evolve

## Measures

- Attenuate variety of the active virus and of antivaccinationists
- Establish a strategy process, as a discourse of S3 with S4
- Involve ministers more tightly in strategy-making
- Cultivate long term orientation and holistic system design
- Implement ongoing evaluation (feedback)
- Assignment of the task force should be for an indefinite period of time

# S5 System Identity and Ethos / Normative Management & the *relationship of Systems* (3 ↔ 4) ↔ 5

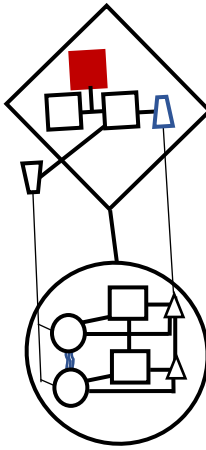

## Actual

- Strong and marked national identity and local identities
- Democratic principles: deeply embodied in the population
- Formal legal «crystallization»: Constitution, Laws (EpG)
- Coherence of citizens' behavior
- Abidance by the recommendations of the authorities (hardly any commands)
- Lack of clarity about the responsibilities in S4 and S3 (Strategic and Executive)
- Parliament and Sovereign hardly involved

## Measures

- Leave legal makeup as it is, but
- Clarify the tasks and competencies of agents in the fight against the pandemic: federal and cantonal councils, crisis staff
- Strengthen enforcement and sanctioning power of federal council in case of crisis?
- Enact interlinkage of S3 and S4 in strategy-making
- A normative discourse about values, beforehand, not at the moment of actual crisis: in Parliament and in the public, involving education system and media

# Information and Communication Systems

## Actual

- Mostly outdated, some are even nonexistent, e.g. no central platform that makes all relevant data accessible
- Availability, timeliness and quality of data suffer
- Testing and vaccination campaigns are compromised
- Important tools don't function properly, e.g., contact tracing / breaking of infection chains
- Monitoring and control of the pandemic impaired and processes in the administration paralyzed

## Measures

- Fundamental redesign necessary
- A central platform that makes all relevant data of the pandemic visible at a glance.
- A Covid-App that is seen by citizens as a help, not as a control device: it acts quickly and reliably, warns and protects
- A reliable, easy-to-use registration platform for people wanting to be vaccinated in all cantons.\*
- Avoid flops such as the vaccination platform "meinimpfungen.ch", which had dramatic security flaws → taken offline immediately
- Enhance «enabling» technologies (communication & conversation )
- P.M.: electronic patient record, data mgt

# Desired Structure Federal Level

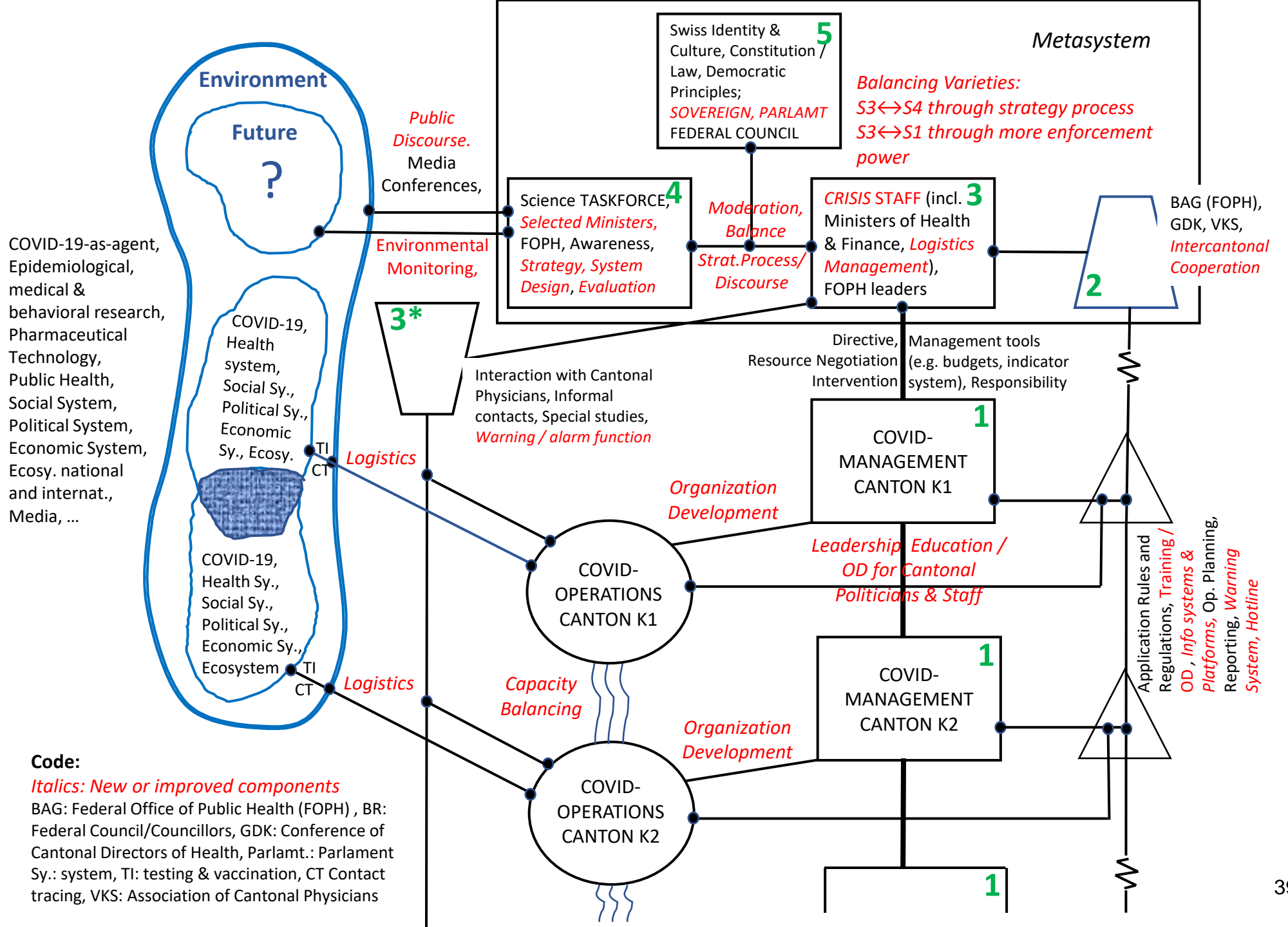

# Cantons AND\* Confederation

Federal Constitution (translation of §43a5/1):

"The Confederation shall assume only those tasks  
which exceed the power of the Cantons  
or which require uniform regulation by the Confederation".

\* not: «VERSUS»



**Covid-induced  
Death Rates**  
per country  
cumulated,  
until 26 Nov 2021

Rank	Country	Deaths per 100'000 population cumulated
1	Belgium	231,6
2	Italy	221,6
3	UK	213,6
<b>4</b>	<b>Europe</b>	<b>188,4</b>
5	Spain	188,1
6	France	183,8
7	Russia	182,2
8	Portugal	178,5
9	Sweden	150,0
10	Austria	137,1
<b>11</b>	<b>Switzerland</b>	<b>132,5</b>
12	Germany	120,5
13	Netherlands	112,5
14	Israel	92,8
15	Denmark	49,4

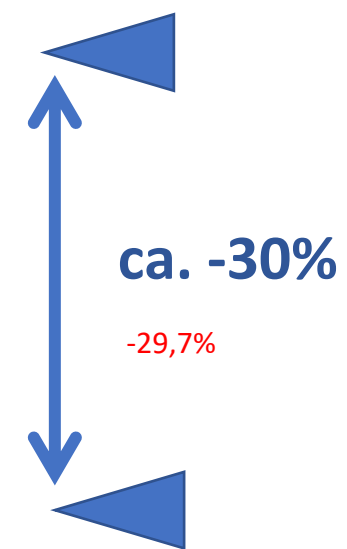

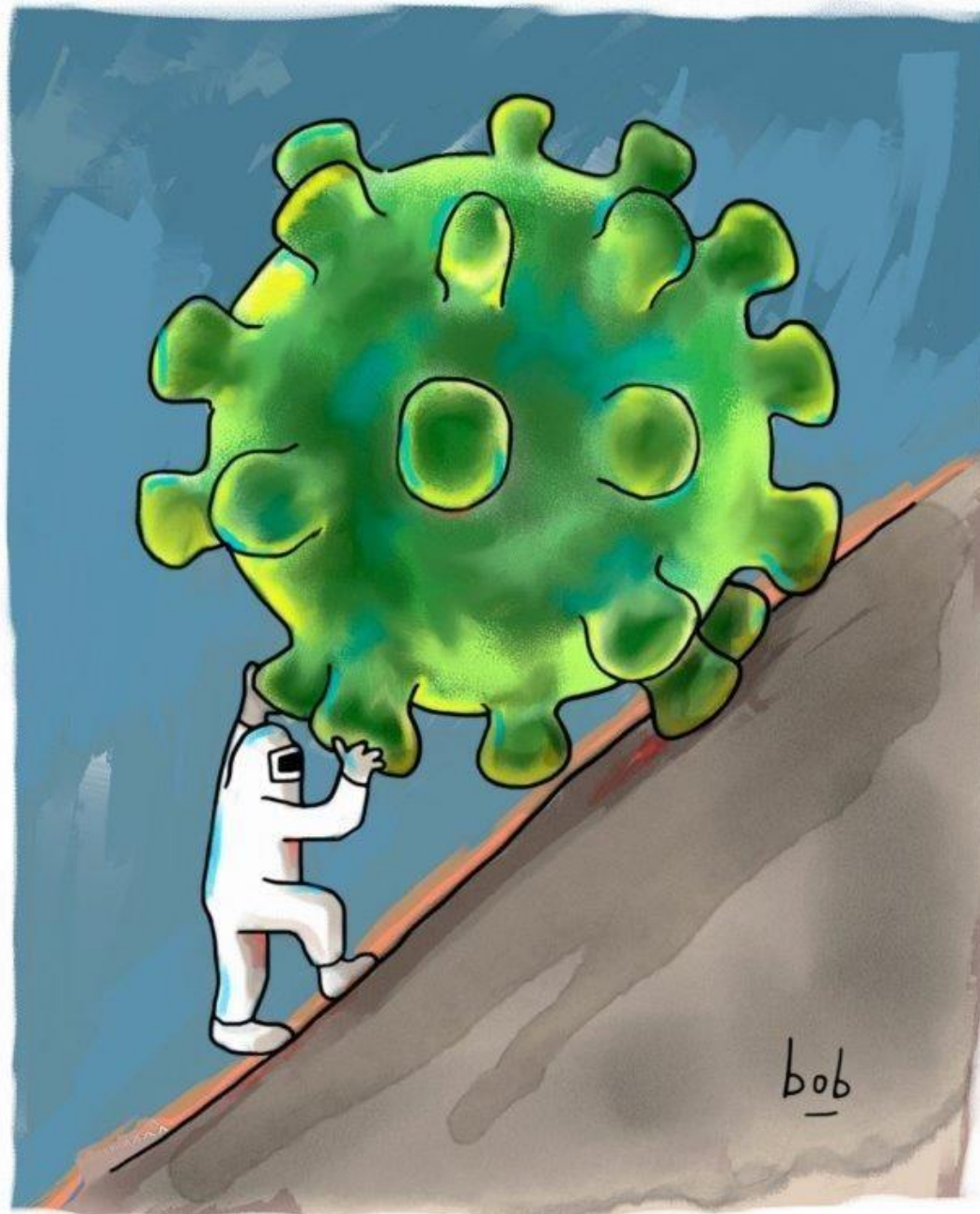

bob

## Forthcoming publications:

Schwaninger, M (2021) Cybernetic Crisis Management in a Federal System – Insights from the Covid Pandemic. Systems Research and Behavioral Science (Publication ca. December 2021).

Tuckermann H & Schwaninger M, eds. (2022) Wege aus der Covid-19-Krise. Bern: Haupt (Date of publication: 17 January 2022).

## Contact:

*[markus.schwaninger@unisg.ch](mailto:markus.schwaninger@unisg.ch)*



- ① First Shutdown: Closure of shops, restaurants and leisure facilities (16 March 2020)
- ② Opening of schools, shops and restaurants (11 May 2020)
- ③ Nationwide closure of restaurants and leisure facilities (22 December 2020)
- ④ Second shutdown. Shop closures and compulsory home office (18 January 2021)
- ⑤ Opening of shops (1 March 2021)
- ⑥ Restaurant terraces open, indoor sports allowed again (19 April 2021)
- ⑦ Open restaurants, relax upper limits on attendance of events and meetings (31 May 2021)
- ⑧ Obligatory certificate in restaurants and leisure institutions (13 September 2021)

# Levels of Recursion - Variant

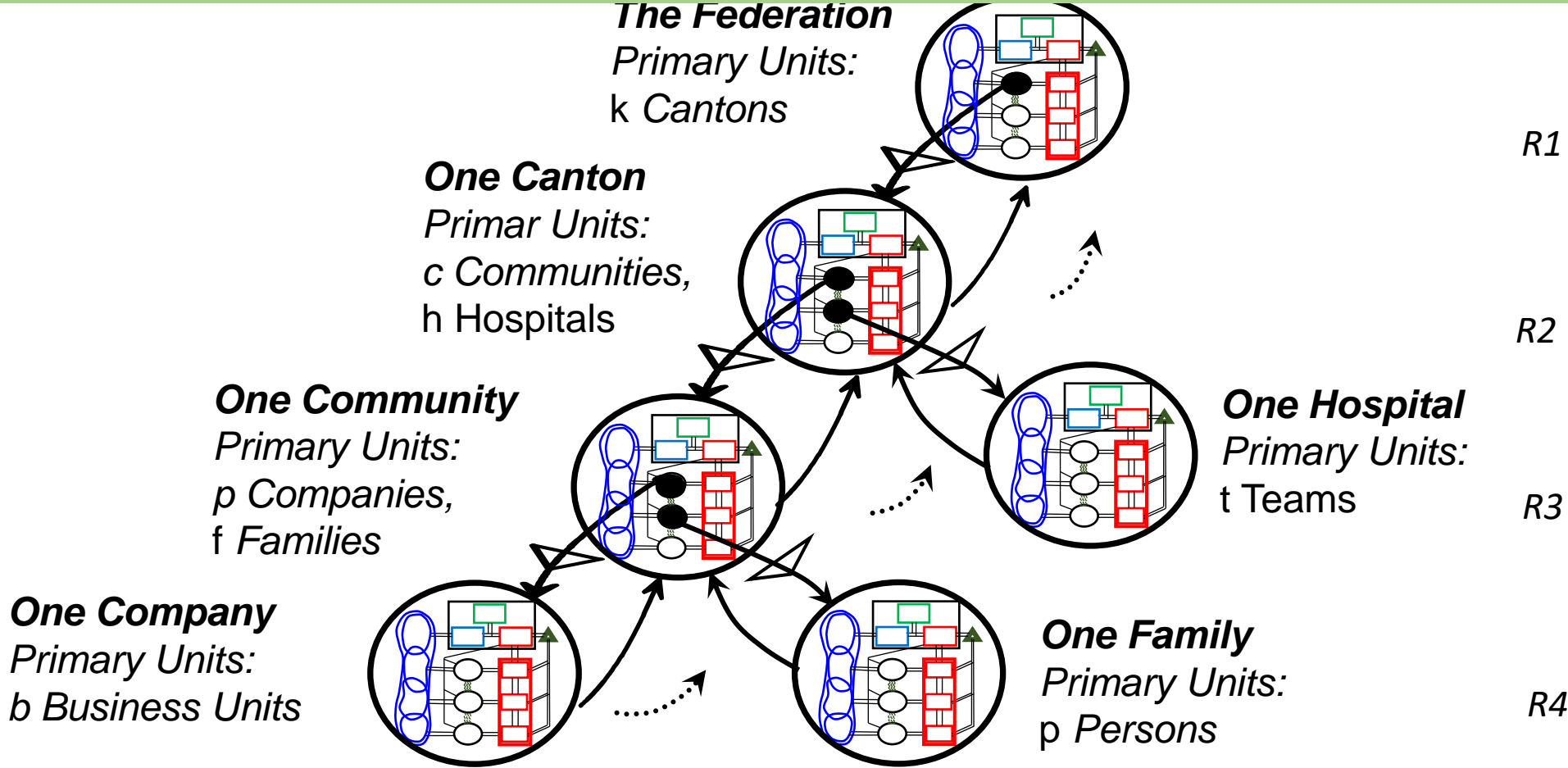

$R$  Level of recursion

Potential connection to higher levels of recursion

# New Corona cases per day (Switzerland)

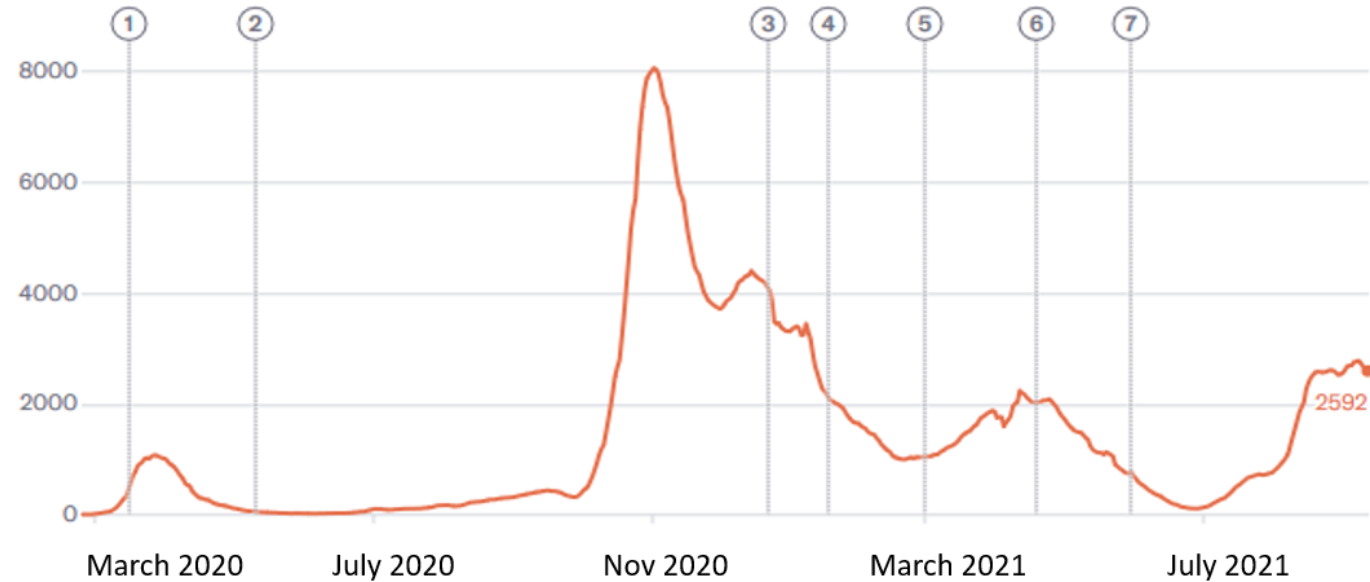

- ① First Shutdown: Closure of shops, restaurants and leisure facilities (16 March 2020)
- ② Opening of schools, shops and restaurants (11 May 2020)
- ③ Nationwide closure of restaurants and leisure facilities (22 December 2020)
- ④ Second shutdown. Shop closures and compulsory home office (18 January 2021)
- ⑤ Opening of shops (1 March 2021)
- ⑥ Restaurant terraces open, indoor sports allowed again (19 April 2021)
- ⑦ Open restaurants, relax upper limits on attendance of events and meetings (31 May 2021)



# Covid-induced Death Rates per country cumulated, until September 2021

Source: BAG-Bundesamt für  
Gesundheit

Rank	Country	Deaths per 100'000 Inhabitants, cumulated
1	Belgium	219
2	Italy	214
3	U.K.	197
4	Spain	182
5	France	176
6	<b>Europe</b>	159
7	Sweden	145
8	Russia	130
9	<b>Switzerland</b>	127
10	Austria	120
11	Germany	111
12	Netherlands	105
13	Israel	82
14	Denmark	45



# Vaccination Coverage November 2021

	Vaccinated at least once	Vaccinated completely
<b>Gibraltar:</b> 25.11.2021***		99%
<b>Portugal:</b> 26.11.2021***		~90%
<b>United Arab Emirates:</b> 15.11.*	98,1%	88,4%
<b>Chile:</b> 23.11.*	87,5	83,3%
<b>Cuba:</b> 22.11.*	89,6%	80,3%.
<b>Spain:</b> 26.11.2021***		~80%
<b>Uruguay:</b> 24.11.*	79,7%	75,8%
<b>Switzerland:</b> 10.11.**		~74%
<b>Germany:</b> 26.11.*	71,0%	68,3%
<b>Sweden:</b> 24.11.****		67,8%

\*<https://www.zdf.de/nachrichten/politik/corona-impfung-daten-100.html>

\*\*BAG. <https://www.cash.ch/news/politik/coronavirus-update-corona-bag-masserey-2g-der-schweiz-derzeit-nicht-gerechtfertigt-2986-neue-faelle-1851534>

\*\*\*Tagesanzeiger 26.11.2021 \*\*\*\*<https://www.google.com/search?client=firefox-b-e&q=sweden+vaccination+rate>

